

SAE TYPE "I"

13/32" Wide Worm Gear Clamp

13/32" band develops concentrated sealing pressure. This narrow band, low profile design accommodates a variety of applications. Band and housing are 300 series stainless steel with 1/4" slotted hex head shouldered screw.



Rated Ultimate Torque: 40in.lbs. min. (4.5Nm)

Recommended Installation Torque: 25-30in.lbs. (2.8-3.4Nm)

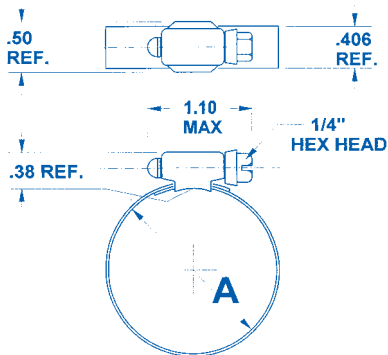

Clamp Part No.	"300" Series Stainless Screws	"A" Diameter Range					
		Decimals		Inches		Millimeters	
		Min.	Max.	Min.	Max.	Min.	Max.
4206	4306	.44	.78	7/16	25/32	11	20
4208	4308	.50	.91	1/2	29/32	13	23
4210	4310	.50	1.06	1/2	1-1/16	13	27
4212	4312	.69	1.25	11/16	1-1/4	18	32
4216	4316	.62	1.50	5/8	1-1/2	19	38
4220	4320	.81	1.75	13/16	1-3/4	21	44
4224	4324	1.06	2.00	1-1/16	2	27	51
4228	4328	1.31	2.25	1-5/16	2-1/4	33	57
4232	4332	1.56	2.50	1-9/16	2-1/2	40	64
4236	4336	1.81	2.75	1-13/16	2-3/4	46	70
4240	4340	2.06	3.00	2-1/16	3	52	76
4244	4344	2.31	3.25	2-5/16	3-1/4	59	83
4248	4348	2.56	3.50	2-9/16	3-1/2	65	89
4252	4352	2.81	3.75	2-13/16	3-3/4	71	95
4256	4356	3.06	4.00	3-1/6	4	78	102

OTHER SIZES AVAILABLE UPON REQUEST • AVAILABLE IN PACKED AND BULK STOCK
OTHER PACKAGING CONFIGURATIONS AVAILABLE

SAE TYPE "I" Extended Band

13/32" Wide Worm Gear Clamp

Designed for Silicone, E.P.D.M. and other soft hose.

The inner band is an integral extension of the 13/32" wide band clamp to create a smooth inner surface that prevents extrusion of soft hose through the slots. Band and housing are 300 series stainless steel with 1/4" slotted hex headed shouldered screw.

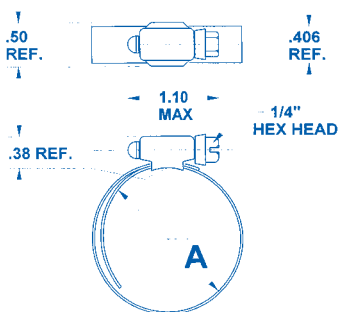

Rated Ultimate Torque: 40in.lbs. min. (4.5Nm)

Recommended Installation Torque: 25-30in.lbs. (2.8-3.4Nm)

Clamp Part No.	"300" Series Stainless Screws	"A" Diameter Range					
		Decimals		Inches		Millimeters	
		Min.	Max.	Min.	Max.	Min.	Max.
4404	4504	.38	.63	3/8	5/8	10	16
4406	4506	.44	.78	7/16	25/32	11	20
4408	4508	.50	.91	1/2	29/32	13	23

OTHER SIZES AVAILABLE UPON REQUEST • AVAILABLE IN PACKED AND BULK STOCK
OTHER PACKAGING CONFIGURATIONS AVAILABLE