

MURRAY

®

MURRAY CORPORATION Clamping Solutions

Dual Bead Super Sealing Clamp - SAE Type "F"

Murray Corporation precision-engineered specialty clamps for various applications. OEM quantities are available directly from Murray.

For air - air & coolant systems. The inner shield provides superb sealing characteristics and is safe for all soft hoses. It can also be found in the marine, agriculture, construction and off-highway markets.

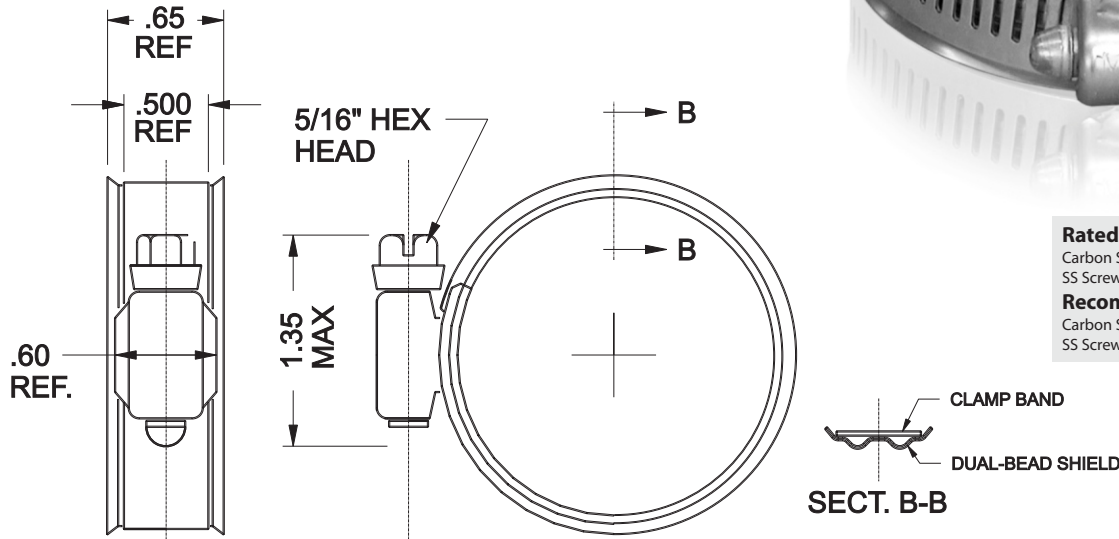

Rated Ultimate Torque:

Carbon Screw 50in.lbs. min. (5.6Nm)
SS Screw 60in.lbs. min. (6.8Nm)

Recommended Installation Torque:

Carbon Screw 30-40in.lbs. (3.4 - 4.5Nm)
SS Screw 35-45in.lbs. (4.0 - 5.1Nm)

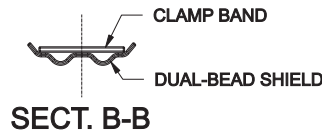

	Part Number		"A" Diameter Range					
	"400" Series	"300" Series	Decimals		Inches		Millimeters	
	Stainless Screws	Stainless Screws	Min.	Max.	Min.	Max.	Min.	Max.
DB 16	DB 16SS	DB 16SS305	0.63	1.38	5/8	1-3/8	15.9	34.9
DB 20	DB 20SS	DB 20SS305	0.69	1.63	11/16	1-5/8	17.5	41.4
DB 24	DB 24SS	DB 24SS305	0.94	1.88	15/16	1-7/8	23.8	47.6
DB 28	DB 28SS	DB 28SS305	1.19	2.13	1-3/16	2-1/8	30.2	54.0
DB 32	DB 32SS	DB 32SS305	1.44	2.38	1-7/16	2-3/8	36.5	60.3
DB 36	DB 36SS	DB 36SS305	1.69	2.63	1-11/16	2-5/8	42.9	66.7
DB 40	DB 40SS	DB 40SS305	1.94	2.88	1-15/16	2-7/8	49.2	73.0
DB 44	DB 44SS	DB 44SS305	2.19	3.13	2-3/16	3-1/8	55.6	79.4
DB 48	DB 48SS	DB 48SS305	2.44	3.38	2-7/16	3-3/8	61.9	85.7
DB 52	DB 52SS	DB 52SS305	2.69	3.63	2-11/16	3-5/8	68.3	92.1
DB 56	DB 56SS	DB 56SS305	2.94	3.88	2-15/16	3-7/8	74.6	98.4
DB 60	DB 60SS	DB 60SS305	3.19	4.13	3-3/16	4-1/8	81.0	104.8
DB 64	DB 64SS	DB 64SS305	3.44	4.38	3-7/16	4-3/8	87.3	111.1
DB 72	DB 72SS	DB 72SS305	3.94	4.88	3-15/16	4-7/8	100.0	123.8
DB 80*	DB 80SS	DB 80SS305	4.44	5.38	4-7/16	5-3/8	112.7	136.5
DB 88*	DB 88SS	DB 88SS305	4.94	5.88	4-15/16	5-7/8	125.4	149.2
DB 96	DB 96SS	DB 96SS305	5.44	6.38	5-7/16	6-3/8	138.1	161.9
DB 104	DB 104SS	DB 104SS305	5.94	6.88	5-15/16	6-7/8	150.8	174.7
DB 116	DB 116SS	DB 116SS305	6.38	7.63	6-3/8	7-5/8	161.9	193.7

Other sizes available upon request. Available in packed and bulk stock. Other packaging configurations available.

*Items not stocked. Special order only.

Patented Product



260 Schilling Circle • Hunt Valley, MD, 21031, USA — Ph: 410-771-0380 • Fax: 410-771-5576

www.murraycorp.com • email: sales@murraycorp.com